

Report No.: 18270BC10257801

APPLICATION FOR LOW VOLTAGE DIRECTIVE REPORT

Client Name : ZHEJIANG YOUQI TECHNOLOGY CO.,LTD.
Address : No.229,Dongda Street, Shanshi ,Daxi town, Wenling
City,Zhejiang Province
Product Name : Lithium-ion Battery
Date : Sept. 26, 2021



Shenzhen Anbotek Compliance Laboratory Limited

Shenzhen Anbotek Compliance Laboratory Limited

Code: AB-BAT-38-b

Address: East of 4/F., Building A, Hourui No.3 Industrial Zone, Xixiang Street, Bao'an District,
Shenzhen, Guangdong, China

Tel:(86)755-26066126 Fax:(86)755-26066021 Email:service@anbotek.com



Hotline

400-003-0500

www.anbotek.com

TEST REPORT**EN 62133-2: 2017****Secondary cells and batteries containing alkaline or other non-acid electrolytes —
Safety requirements for portable sealed secondary cells, and for batteries made from them, for
use in portable applications-Part2: Lithium systems****Report**

Reference No.....: 18270BC10257801

Compiled by (+ signature).....: Lucy Zeng / Project Engineer

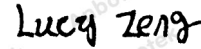

Approved by (+ signature).....: Dely Yang / Project Engineer



Date of issue.....: Sept. 26, 2021

Contents.....: 25 pages (including 3 pages of photos)

Testing laboratory

Name.....: Shenzhen Anbotek Compliance Laboratory Limited

Address.....: East of 4/F., Building A, Hourui No.3 Industrial Zone, Xixiang
Street, Bao'an District, Shenzhen, Guangdong, China

Testing location.....: Shenzhen Anbotek Compliance Laboratory Limited

Client

Name.....: ZHEJIANG YOUQI TECHNOLOGY CO.,LTD.

Address.....: No.229,Dongda Street, Shanshi ,Daxi town, Wenling
City,Zhejiang Province**Test specification**

Standard.....: EN 62133-2: 2017

Test procedure: Compliance with EN 62133-2: 2017

Non-standard test method.....: N.A.

Test item

Description.....: Lithium-ion Battery

Trademark.....: N.A.

Model and/or type reference.....: BYQ-39-A

Manufacturer.....: Shenzhen World New Powr Co.,Ltd

Address.....: Unit A,3/F,Buliding 1, Xusheng industrial Park, liyuan industrial
Zone, Langxin Community Brickyard, Shiyan Street, Bao'an
District, 518108 Shenzhen,Guangdong PEOPLE'S REPUBLIC
OFCHINA

Factory.....: Same as manufacturer

Address.....: Same as manufacturer

Rating(s).....: 36V, 7.5Ah, 270Wh

<p>Particulars: test item vs. test requirements</p>	
Ambient temperature.....	: 20°C ± 5°C.
<p>Test case verdicts</p>	
Test case does not apply to the test object.....	: N (.A.)
Test item does meet the requirement.....	: P (ass)
Test item does not meet the requirement.....	: F (ail)
<p>Testing</p>	
Date of receipt of test item	: Sept. 07, 2021
Date(s) of performance of test.....	: Sept. 07, 2021 to Sept. 22, 2021
<p>General remarks</p>	
<p>This test report shall not be reproduced except in full without the written approval of the testing laboratory.</p>	
<p>The test results presented in this report are only relevant to the test sample.</p>	
<p>"(see remark #)" refers to a remark appended to the report.</p>	
<p>"(see appended table)" refers to a table appended to the report.</p>	
<p>Throughout this report a dot is used as the decimal separator.</p>	
<p><u>Construction:</u></p>	
<p>Battery(Unit:mm)</p>	

Circuit diagram:

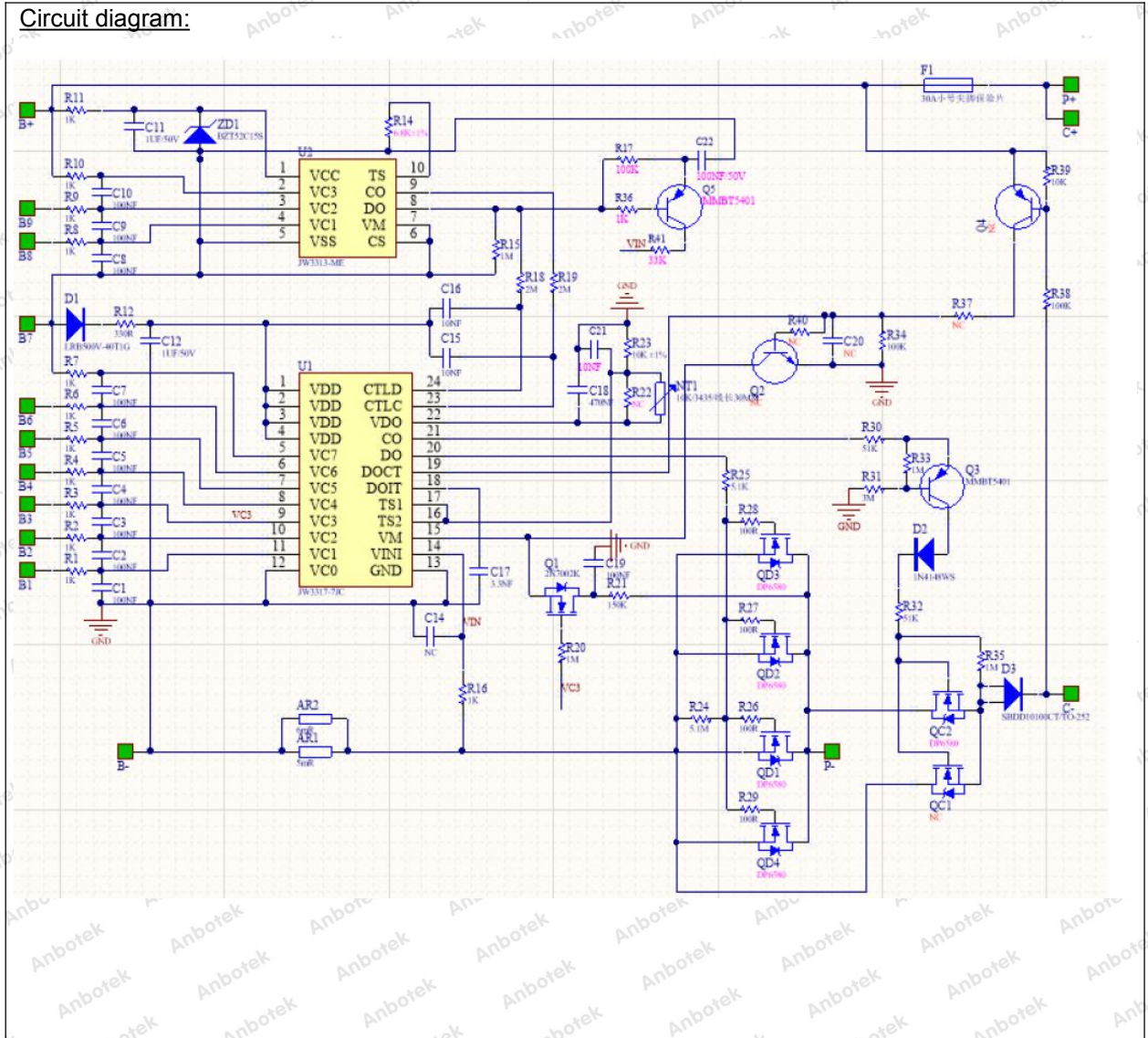

Copy of marking plate:

The artwork below may be only a draft.

Lithium-ion Battery
BYQ-39-A 10INR19/66-3
36V, 7.5Ah, 270Wh
(+), (-)
Shenzhen World New Power Co.,Ltd
2021.08
CAUTION
-Do not disassemble or modify
-Do not short-circuit
-Do not dispose in fire
-Do not expose to high temperature



General product information and other remarks:

This battery is constructed with thirty lithium-ion cells (10S3P), and has overcharge, over-discharge, over current and short-circuits proof circuit.

The main features of the battery are shown as below (clause 7.1.1):

Model	Nominal capacity	Nominal voltage	Nominal Charge Current	Nominal Discharge Current	Maximum Charge Current	Maximum Discharge Current	Maximum Charge Voltage	Final Voltage
BYQ-39-A	7.5Ah	36V	1.5A	7.5A	2A	15A	42V	27.5V

The main features of the cell in the battery are shown as below (clause 7.1.1):

Model	Nominal capacity	Nominal voltage	Nominal Charge Current	Nominal Discharge Current	Maximum Charge Current	Maximum Discharge Current	Maximum Charge Voltage	Final Voltage
INR18650S-2500mAh	2.5Ah	3.6V	0.75A	2.5A	1.25A	7.5A	4.2V	2.75V

The main features of the cell in the battery are shown as below (clause 7.1.2):

Model	Upper limit charge voltage	Taper-off current	Lower charge temperature	Upper charge temperature
INR18650S-2500mAh	4.2V	0.125A	0°C	45°C

EN 62133-2: 2017

Clause	Requirement + Test	Result - Remark	Verdict
4	PARAMETER MEASUREMENT TOLERANCES		P
	Parameter measurement tolerances		P
5	GENERAL SAFETY CONSIDERATIONS		P
5.1	General		P
	Cells and batteries so designed and constructed that they are safe under conditions of both intended use and reasonably foreseeable misuse		P
5.2	Insulation and wiring		P
	The insulation resistance between the positive terminal and externally exposed metal surfaces of the battery (excluding electrical contact surfaces) is not less than 5 MΩ		N
	Insulation resistance (MΩ)..... :		—
	Internal wiring and insulation are sufficient to withstand maximum anticipated current, voltage and temperature requirements		P
	Orientation of wiring maintains adequate clearance and creepage distances between conductors		P
	Mechanical integrity of internal connections accommodates reasonably foreseeable misuse		P
5.3	Venting		P
	Battery cases and cells incorporate a pressure relief mechanism or are constructed so that they relieve excessive internal pressure at a value and rate that will preclude rupture, explosion and self-ignition	Venting mechanism exists on the top of cell.	P
	Encapsulation used to support cells within an outer casing does not cause the battery to overheat during normal operation nor inhibit pressure relief		P
5.4	Temperature, voltage and current management		P
	Batteries are designed such that abnormal temperature rise conditions are prevented	Overcharge, over discharge, over current and short-circuit proof circuit used in this battery. See tests of clause 7.	P
	Batteries are designed to be within temperature, voltage and current limits specified by the cell manufacturer	See above.	P
	Batteries are provided with specifications and charging instructions for equipment manufacturers so that specified chargers are designed to maintain charging within the temperature, voltage and current limits specified	The charging limits specified in the user manual.	P

EN 62133-2: 2017			
Clause	Requirement + Test	Result - Remark	Verdict
5.5	Terminal contacts		P
	The size and shape of the terminal contacts ensure that they can carry the maximum anticipated current	DC terminal contacts complied with the requirements.	P
	External terminal contact surfaces are formed from conductive materials with good mechanical strength and corrosion resistance	DC connector complied with the requirements.	P
	Terminal contacts are arranged to minimize the risk of short-circuit		P
5.6	Assembly of cells into batteries		P
5.6.1	General		P
	Each battery have an independent control and protection for current, voltage, temperature and any other parameter required for safety and to maintain the cells within their operating region	Protective circuit equipped on battery.	P
	This protection may be provided external to the battery such as within the charger or the end devices		N
	If protection is external to the battery, the manufacturer of the battery provide this safety relevant information to the external device manufacturer for implementation		N
	If there is more than one battery housed in a single battery case, each battery have protective circuitry that can maintain the cells within their operating regions	10S3P	P
	Manufacturers of cells specify current, voltage and temperature limits so that the battery manufacturer/designer may ensure proper design and assembly	Current, voltage and temperature limits specified by cell manufacturer.	P
	Batteries that are designed for the selective discharge of a portion of their series connected cells incorporate circuitry to prevent operation of cells outside the limits specified by the cell manufacturer		N
	Protective circuit components added as appropriate and consideration given to the end-device application		P
	The manufacturer of the battery provide a safety analysis of the battery safety circuitry with a test report including a fault analysis of the protection circuit under both charging and discharging conditions confirming the compliance		P
5.6.2	Design recommendation		P

EN 62133-2: 2017

Clause	Requirement + Test	Result - Remark	Verdict
	For the battery consisting of a single cell or a single cellblock, it is recommended that the charging voltage of the cell does not exceed the upper limit of the charging voltage specified in Table 2		N
	For the battery consisting of series-connected plural single cells or series-connected plural cellblocks, it is recommended that the voltages of any one of the single cells or single cellblocks does not exceed the upper limit of the charging voltage, specified in Table 2, by monitoring the voltage of every single cell or the single cellblocks	Charging voltage of each cell block: 4.2V, not exceed 4.2V specified in Clause 7.1.2, Table 2.	P
	For the battery consisting of series-connected plural single cells or series-connected plural cellblocks, it is recommended that charging is stopped when the upper limit of the charging voltage is exceeded for any one of the single cells or single cellblocks by measuring the voltage of every single cell or the single cellblocks		N
	For batteries consisting of series-connected cells or cell blocks, nominal charge voltage not be counted as an overcharge protection		N
	For batteries consisting of series-connected cells or cell blocks, cells have closely matched capacities, be of the same design, be of the same chemistry and be from the same manufacturer		N
	It is recommended that the cells and cell blocks not discharged beyond the cell manufacturer's specified final voltage	Final voltage of battery: 27.5V, not exceed the final voltage specified by cell manufacturer.	P
	For batteries consisting of series-connected cells or cell blocks, cell balancing circuitry incorporated into the battery management system		N
5.6.3	Mechanical protection for cells and components of batteries		P
	Mechanical protection for cells, cell connections and control circuits within the battery provided to prevent damage as a result of intended use and reasonably foreseeable misuse	Mechanical protection for cell connections and control circuits provided.	P
	The mechanical protection can be provided by the battery case or it can be provided by the end product enclosure for those batteries intended for building into an end product		N
	The battery case and compartments housing cells designed to accommodate cell dimensional tolerances during charging and discharging as recommended by the cell manufacturer		N

EN 62133-2: 2017

Clause	Requirement + Test	Result - Remark	Verdict
	For batteries intended for building into a portable end product, testing with the battery installed within the end product considered when conducting mechanical tests		N
5.7	Quality plan		P
	The manufacturer prepares and implements a quality plan that defines procedures for the inspection of materials, components, cells and batteries and which covers the whole process of producing each type of cell or battery		P
5.8	Battery safety components		N
	According annex F		N

6	TYPE TEST AND SAMPLE SIZE		P
	Tests are made with the number of cells or batteries specified in Table 1 using cells or batteries that are not more than six months old		P
	Coin cells with resistance $\leq 3 \Omega$ (measured according annex D) are tested according table 1	Not coin cells	N
	Unless otherwise specified, tests are carried out in an ambient temperature of $20^{\circ}\text{C} \pm 5^{\circ}\text{C}$	Tests are carried out at $20^{\circ}\text{C} \pm 5^{\circ}\text{C}$.	P
	The safety analysis of 5.6.1 identify those components of the protection circuit that are critical for short-circuit, overcharge and overdischarge protection		P
	When conducting the short-circuit test, consideration given to the simulation of any single fault condition that is likely to occur in the protecting circuit that would affect the short-circuit test	See clause 7.3.2.	P

7	SPECIFIC REQUIREMENTS AND TESTS		P
7.1	Charging procedure for test purposes	Lithium system.	P
7.1.1	First procedure		P
	This charging procedure applies to subclauses other than those specified in 7.1.2		P
	Unless otherwise stated in this document, the charging procedure for test purposes is carried out in an ambient temperature of $20^{\circ}\text{C} \pm 5^{\circ}\text{C}$, using the method declared by the manufacturer		P
	Prior to charging, the battery have been discharged at $20^{\circ}\text{C} \pm 5^{\circ}\text{C}$ at a constant current of 0,2 It A down to a specified final voltage		P
7.1.2	Second procedure		P

EN 62133-2: 2017

Clause	Requirement + Test	Result - Remark	Verdict
	This charging procedure applies only to 7.3.1, 7.3.4, 7.3.5 and 7.3.9		P
	After stabilization for 1 h and 4 h, respectively, at ambient temperature of highest test temperature and lowest test temperature, as specified in Table 2, cells are charged by using the upper limit charging voltage and maximum charging current, until the charging current is reduced to 0,05 It A, using a constant voltage charging method	Charge temperature 0-45°C declared.	P
7.2	Intended use		P
7.2.1	Continuous charging at constant voltage (cells)	Test complied.	P
	Fully charged cells are subjected for 7 days to a charge using the charging method for current and standard voltage specified by the cell manufacturer		P
	Results: No fire. No explosion. No leakage..... :	(See appended table 7.2.1)	P
7.2.2	Case stress at high ambient temperature (battery)		P
	Oven temperature (°C)..... :	70°C	—
	Results: No physical distortion of the battery case resulting in exposure of internal protective components and cells	(See appended table 7.2.2)	P
7.3	Reasonably foreseeable misuse		P
7.3.1	External short-circuit (cell)	Tested complied.	P
	The cells were tested until one of the following occurred:		P
	- 24 hours elapsed; or		N
	- The case temperature declined by 20 % of the maximum temperature rise		P
	Results: No fire. No explosion..... :	(See appended table 7.3.1)	P
7.3.2	External short-circuit (battery)	Tested complied.	P
	The batteries were tested until one of the following occurred:		P
	- 24 hours elapsed; or		P
	- The case temperature declined by 20 % of the maximum temperature rise		N
	In case of rapid decline in short circuit current, the battery pack remained on test for an additional one hour after the current reached a low end steady state condition		N

EN 62133-2: 2017

Clause	Requirement + Test	Result - Remark	Verdict
	A single fault in the discharge protection circuit conducted on one to four (depending upon the protection circuit) of the five samples before conducting the short-circuit test	Single fault conducted on two samples.	P
	A single fault applies to protective component parts such as MOSFET, fuse, thermostat or positive temperature coefficient (PTC) thermistor	Single fault applies on MOSFET (QD1), see appended table 7.3.2.	P
	Results: No fire. No explosion..... :	(See appended table 7.3.2)	P
7.3.3	Free fall	Tested complied.	P
	Results: No fire. No explosion	No fire. No explosion	P
7.3.4	Thermal abuse (cells)	Tested complied.	P
	Oven temperature (°C)..... :	130°C	—
	Results: No fire. No explosion	No fire. No explosion	P
7.3.5	Crush (cells)	Tested complied.	P
	The crushing force was released upon:		P
	- The maximum force of 13 kN ± 0,78 kN has been applied; or		P
	- An abrupt voltage drop of one-third of the original voltage has been obtained		N
	Results: No fire. No explosion..... :	(See Table 7.3.5)	P
7.3.6	Over-charging of battery	Tested complied.	P
	The supply voltage which is:		P
	- 1,4 times the upper limit charging voltage presented in Table A.1 (but not to exceed 6,0 V) for single cell/cell block batteries or		N
	- 1,2 times the upper limit charging voltage resented in Table A.1 per cell for series connected multi-cell batteries, and	50.4V applied.	P
	- Sufficient to maintain a current of 2,0 It A throughout the duration of the test or until the supply voltage is reached		P
	Test was continued until the temperature of the outer casing:		N
	- Reached steady state conditions (less than 10°C change in 30-minute period); or		P
	- Returned to ambient		N
	Results: No fire. No explosion..... :	(See appended table 7.3.6)	P
7.3.7	Forced discharge (cells)	Tested complied.	P

EN 62133-2: 2017

Clause	Requirement + Test	Result - Remark	Verdict
	If the discharge voltage reaches the negative value of upper limit charging voltage within the testing duration, the voltage is maintained at the negative value of the upper limit charging voltage by reducing the current for the remainder of the testing duration		N
	If the discharge voltage does not reach the negative value of upper limit charging voltage within the testing duration, the test is terminated at the end of the testing duration		P
	Results: No fire. No explosion..... :	(See appended table 7.3.7)	P
7.3.8	Mechanical tests (batteries)		P
7.3.8.1	Vibration	Tested complied.	P
	Results: No fire, no explosion, no rupture, no leakage or venting..... :	(See appended table 7.3.8.1)	P
7.3.8.2	Mechanical shock	Tested complied.	P
	Results: No leakage, no venting, no rupture, no explosion and no fire..... :	(See appended table 7.3.8.2)	P
7.3.9	Design evaluation – Forced internal short-circuit (cells)	Tested complied.	P
	The cells complied with national requirement for..... :	For France, Japan, Republic of Korea and Switzerland.	—
	The pressing was stopped upon:		P
	- A voltage drop of 50 mV has been detected; or		N
	- The pressing force of 800 N (cylindrical cells) or 400 N (prismatic cells) has been reached	800N for prismatic cells.	P
	Results: No fire..... :	(See appended table 7.3.9)	P

8	INFORMATION FOR SAFETY		P
8.1	General		P
	Manufacturers of secondary cells ensure that information is provided about current, voltage and temperature limits of their products	Safety information mentioned in the manufacturer's specifications.	P
	Manufacturers of batteries ensure that equipment manufacturers and, in the case of direct sales, end-users are provided with information to minimize and mitigate hazards	Safety information mentioned in the manufacturer's specifications.	P
	Systems analyses performed by device manufacturers to ensure that a particular battery design prevents hazards from occurring during use of a product		N

EN 62133-2: 2017

Clause	Requirement + Test	Result - Remark	Verdict
	As appropriate, any information relating to hazard avoidance resulting from a system analysis provided to the end user		N
	Do not allow children to replace batteries without adult supervision		N
8.2	Small cell and battery safety information	Not small cell and battery.	N
	The following warning language is to be provided with the information packaged with the small cells and batteries or equipment using them:		N
	- Keep small cells and batteries which are considered swallowable out of the reach of children		N
	- Swallowing may lead to burns, perforation of soft tissue, and death. Severe burns can occur within 2 h of ingestion		N
	- In case of ingestion of a cell or battery, seek medical assistance promptly		N

9*	MARKING		P
9.1	Cell marking	The final product is battery	N
	Cells marked as specified in IEC 61960, except coin cells		N
	Coin cells whose external surface area is too small to accommodate the markings on the cells show the designation and polarity		N
	By agreement between the cell manufacturer and the battery and/or end product manufacturer, component cells used in the manufacture of a battery need not be marked		N
9.2	Battery marking		P
	Batteries marked as specified in IEC 61960, except for coin batteries	See marking plate on page 4.	P
	Coin batteries whose external surface area is too small to accommodate the markings on the batteries show the designation and polarity. Batteries also marked with an appropriate caution statement		N
	Terminals have clear polarity marking on the external surface of the battery	See page 5.	P
	Batteries with keyed external connectors designed for connection to specific end products need not be marked with polarity markings if the design of the external connector prevents reverse polarity connections		N

EN 62133-2: 2017

Clause	Requirement + Test	Result - Remark	Verdict
9.3	Caution for ingestion of small cells and batteries	Not small cell and battery.	N
	Coin cells and batteries identified as small batteries according to 8.2 include a caution statement regarding the hazards of ingestion in accordance with 8.2		N
	When small cells and batteries are intended for direct sale in consumer-replaceable applications, caution for ingestion given on the immediate package		N
9.4	Other information		P
	Storage and disposal instructions	Information for recommended charging instructions mentioned in manufacturer's specifications.	P
	Recommended charging instructions	Information for recommended charging instructions mentioned in manufacturer's specifications.	P

10	PACKAGING AND TRANSPORT		P
	Packaging for coin cells not small enough to fit within the limits of the ingestion gauge of Figure 3	Not coin cells.	N
	The materials and packaging design are chosen so as to prevent the development of unintentional electrical conduction, corrosion of the terminals and ingress of environmental contaminants		P

ANNEX A	CHARGING AND DISCHARGING RANGE OF SECONDARY LITHIUM ION CELLS FOR SAFE USE		P
A.1	General		P
A.2	Safety of lithium ion secondary battery	Complied.	P
A.3	Consideration on charging voltage	Complied.	P
A.3.1	General	Charging voltage is 4.2V	P
A.3.2	Upper limit charging voltage	4.2V	P
A.3.2.1	General		P
A.3.2.2	Explanation of safety viewpoint		N
A.3.2.3	Safety requirements, when different upper limit charging voltage is applied	4.2V applied.	N
A.4	Consideration of temperature and charging current		P
A.4.1	General		P

EN 62133-2: 2017

Clause	Requirement + Test	Result - Remark	Verdict
A.4.2	Recommended temperature range	See A.4.2.2.	P
A.4.2.1	General		P
A.4.2.2	Safety consideration when a different recommended temperature range is applied	Charging temperature declared by client is: 0-45°C	P
A.4.3	High temperature range	Not higher than the temperature range specific in this standard.	N
A.4.3.1	General		N
A.4.3.2	Explanation of safety viewpoint		N
A.4.3.3	Safety considerations when specifying charging conditions in the high temperature range		N
A.4.3.4	Safety considerations when specifying a new upper limit in the high temperature range		N
A.4.4	Low temperature range	Charging lower temperature declared by client is: 0°C	P
A.4.4.1	General		P
A.4.4.2	Explanation of safety viewpoint		P
A.4.4.3	Safety considerations, when specifying charging conditions in the low temperature range		P
A.4.4.4	Safety considerations when specifying a new lower limit in the low temperature range	-5°C applied	P
A.4.5	Scope of the application of charging current		P
A.4.6	Consideration of discharge		P
A.4.6.1	General		P
A.4.6.2	Final discharge voltage and explanation of safety viewpoint	Cell specified final voltage 2.75V.	P
A.4.6.3	Discharge current and temperature range		P
A.4.6.4	Scope of application of the discharging current		P
A.5	Sample preparation		P
A.5.1	General		P
A.5.2	Insertion procedure for nickel particle to generate internal short		P
A.5.3	Disassembly of charged cell		P
A.5.4	Shape of nickel particle		P
A.5.5	Insertion of nickel particle in cylindrical cell		P
A.5.5.1	Insertion of nickel particle in winding core		P
A.5.5.2	Marking the position of the nickel particle on both ends of the winding core of the separator		P

Code: AB-BAT-38-b

Shenzhen Anbotek Compliance Laboratory Limited

Address: East of 4/F., Building A, Hourui No.3 Industrial Zone, Xixiang Street, Bao'an District, Shenzhen, Guangdong, China
 Tel: (86)755-26066126 Fax: (86)755-26066021 Email: service@anbotek.com

Hotline
 400-003-0500
 www.anbotek.com

EN 62133-2: 2017

Clause	Requirement + Test	Result - Remark	Verdict
A.5.6	Insertion of nickel particle in prismatic cell		N
A.6	Experimental procedure of the forced internal short-circuit test		P
A.6.1	Material and tools for preparation of nickel particle		P
A.6.2	Example of a nickel particle preparation procedure		P
A.6.3	Positioning (or placement) of a nickel particle		P
A.6.4	Damaged separator precaution		P
A.6.5	Caution for rewinding separator and electrode		P
A.6.6	Insulation film for preventing short-circuit		P
A.6.7	Caution when disassembling a cell		P
A.6.8	Protective equipment for safety		P
A.6.9	Caution in the case of fire during disassembling		P
A.6.10	Caution for the disassembling process and pressing the electrode core		P
A.6.11	Recommended specifications for the pressing device		P
ANNEX B	RECOMMENDATIONS TO EQUIPMENT MANUFACTURERS AND BATTERY ASSEMBLERS		N
ANNEX C	RECOMMENDATIONS TO THE END-USERS		N
ANNEX D	MEASUREMENT OF THE INTERNAL AC RESISTANCE FOR COIN CELLS		N
D.1	General		N
D.2	Method		N
	A sample size of three coin cells is required for this measurement.....	(See appended table D.2)	N
	Coin cells with an internal resistance of less than or equal to 3 Ω are subjected to the testing according to Clause 6 and Table 1		N
	Coin cells with an internal resistance greater than 3 Ω require no further testing		N
ANNEX E	PACKAGING AND TRANSPORT		N
ANNEX F	COMPONENT STANDARDS REFERENCES		N

TABLE: List of critical components					P
Object/part No.	Manufacturer/trademark	Type/model	Technical data	Standard (Edition / year)	Mark(s) of conformity ¹
Cell	Shenzhen World New Powr Co.,Ltd	INR18650S -2500mAh	3.6V, 2500mAh	EN 62133-2: 2017	Tested with appliance

1) An asterisk indicates a mark which assures the agreed level of surveillance.

7.2.1	TABLE: Continuous charging at constant voltage (cells)			P
Sample No.	Recommended charging voltage V _c , (Vdc)	Recommended charging current I _{rec} , (mA)	OCV at start of test, (Vdc)	Results
C1	4.20	750	4.18	P
C2	4.20	750	4.17	P
C3	4.20	750	4.17	P
C4	4.20	750	4.18	P
C5	4.20	750	4.18	P

Supplementary information:
 - No fire or explosion
 - No leakage

7.2.2	TABLE: Moulded case stress at high ambient temperature (battery)		P
Sample No.	OCV at start of test, (Vdc)	OCV at start of test, (Vdc)	Results
B20	41.86	41.63	P
B21	41.85	41.65	P
B22	41.83	41.66	P

Supplementary information:
 - No fire or explosion
 - No leakage
 - Others (please explain)

7.3.1	TABLE: External short circuit (cell)				P
Sample No.	Ambient T(°C)	OCV at start of test, (Vdc)	Resistance of circuit, (mΩ)	Maximum case temperature (°C)	Results
Charging temperature: -5°C					
C6	55.5	4.08	86.4	113.6	P
C7	55.5	4.08	82.6	118.2	P
C8	55.5	4.07	87.1	115.4	P
C9	55.5	4.08	89.3	116.9	P
C10	55.5	4.07	88.4	112.7	P

Charging temperature: 45°C					
C11	55.8	4.16	83.2	120.3	P
C12	55.8	4.17	82.5	122.7	P
C13	55.8	4.16	86.9	120.9	P
C14	55.8	4.17	82.7	121.4	P
C15	55.8	4.17	83.1	121.8	P

Supplementary information:

- No fire or explosion

7.3.2	TABLE: External short-circuit (battery)					P
Sample No.	Ambient T (°C)	OCV before test (Vdc)	Resistance of circuit (mΩ)	Maximum case temperature (°C)	Component single fault condition	Results
B1	23.0	41.86	86.1	23.3	--	P
B2	23.0	41.85	82.5	23.5	--	P
B3	23.0	41.85	87.1	23.3	--	P
B4	23.0	41.87	88.3	23.9	S-C MOSFET QD1	P
B5	23.0	41.84	86.4	23.7	S-C MOSFET QD1	P

Supplementary information:

- No fire or explosion
- Others (S-C=Short circuit)

7.3.3	TABLE: Free fall		P
Sample No.	OCV at start of test, (Vdc)	OCV at removal of thermal free fall, (Vdc)	Results
C16	4.17	4.17	P
C17	4.18	4.18	P
C18	4.18	4.18	P
B6	41.85	41.88	P
B7	41.86	41.86	P
B8	41.86	41.86	P

Supplementary information:

- No fire or explosion

7.3.4	TABLE: Thermal abuse (cells)			P
Sample No.	OCV at start of test, (Vdc)	Ambient T(°C)	Temperature raised at a rate(°C)	Results
Charging temperature: -5°C				
C19	4.08	130±2	5°C/min	P

C20	4.08	130±2	5°C/min	P
C21	4.09	130±2	5°C/min	P
C22	4.07	130±2	5°C/min	P
C23	4.08	130±2	5°C/min	P
Charging temperature: 45°C				
C24	4.16	130±2	5°C/min	P
C25	4.16	130±2	5°C/min	P
C26	4.17	130±2	5°C/min	P
C27	4.17	130±2	5°C/min	P
C28	4.16	130±2	5°C/min	P
Supplementary information: - No fire or explosion				

7.3.5	TABLE: Crush (cells)			P
Sample No.	OCV before test (Vdc)	OCV at removal of crushing force (Vdc)	Maximum force applied to the cell during crush (kN)	Results
Charging temperature: -5°C				
C29	4.07	4.07	13.2	P
C30	4.08	4.08	13.3	P
C31	4.08	4.08	13.3	P
C32	4.08	4.08	13.1	P
C33	4.09	4.09	13.1	P
Charging temperature: 45°C				
C34	4.17	4.17	13.2	P
C35	4.17	4.17	13.1	P
C36	4.18	4.17	13.2	P
C37	4.16	4.16	13.2	P
C38	4.17	4.17	13.1	P
Supplementary information:s - No fire or explosion				

7.3.6	TABLE: Over-charging of battery			P
Constant charging current (A).....:			15.0	—
Supply voltage (Vdc).....:			50.4	—
Sample No.	OCV before charging (Vdc)	Total charging time (minute)	Maximum outer case temperature (°C)	Results
B9	33.2	82	32.2	P

B10	32.8	82	33.2	P
B11	32.3	82	33.9	P
B12	32.5	82	32.5	P
B13	32.7	82	31.8	P

Supplementary information:

- No fire or explosion

7.3.7	TABLE: Forced discharge (cells)			P
Sample No.	OCV before application of reverse charge (Vdc)	Measured reverse charge I_r (A)	Lower limit discharge voltage (Vdc)	Results
C39	3.31	2.5	2.75	P
C40	3.25	2.5	2.75	P
C41	3.22	2.5	2.75	P
C42	3.29	2.5	2.75	P
C43	3.24	2.5	2.75	P

Supplementary information:

- No fire or explosion

7.3.8.1	TABLE: Vibration				P
Sample No.	OCV before test (Vdc)	OCV after test (Vdc)	Mass before test (g)	Mass after test (g)	Results
B14	41.85	41.85	1795.53	1795.53	P
B15	41.86	41.86	1794.36	1794.36	P
B16	41.85	41.85	1783.64	1783.64	P

Supplementary information:

- No fire or explosion
- No rupture
- No leakage
- No venting

7.3.8.2	TABLE: Mechanical shock				P
Sample No.	OCV before test (Vdc)	OCV after test (Vdc)	Mass before test (g)	Mass after test (g)	Results
B17	41.84	41.84	1792.14	1792.14	P
B18	41.85	41.85	1789.42	1789.42	P
B19	41.86	41.86	1794.31	1794.31	P

Supplementary information:

- No fire or explosion
- No rupture
- No leakage
- No venting

7.3.9 TABLE: Forced internal short circuit (cells)					P
Sample No.	Chamber ambient T (°C)	OCV before test (Vdc)	Particle location ¹⁾	Maximum applied pressure (N)	Results
Charging temperature: -5°C					
C44	-5	4.07	1	800	P
C45	-5	4.08	1	800	P
C46	-5	4.08	1	800	P
C47	-5	4.08	1	800	P
C48	-5	4.07	1	800	P
Charging temperature: 45°C					
C49	45	4.17	1	800	P
C50	45	4.16	1	800	P
C51	45	4.17	1	800	P
C52	45	4.18	1	800	P
C53	45	4.17	1	800	P
Supplementary information:					
¹⁾ Identify one of the following:					
1: Nickel particle inserted between positive and negative (active material) coated area.					
2: Nickel particle inserted between positive aluminium foil and negative active material coated area.					
- No fire or explosion					

D.2 TABLE: Internal AC resistance for coin cells					N
Sample No.	Ambient T (°C)	Store time (h)	Resistance Rac (Ω)	Results ¹⁾	
--	--	--	--	--	
--	--	--	--	--	
--	--	--	--	--	
Supplementary information:					
¹⁾ Coin cells with internal resistance less than or equal to 3 Ω, see test result on corresponding tables					

Photo 1

- front
- rear
- right side
- left side
- top
- bottom
- internal



Photo 2

- front
- rear
- right side
- left side
- top
- bottom
- internal

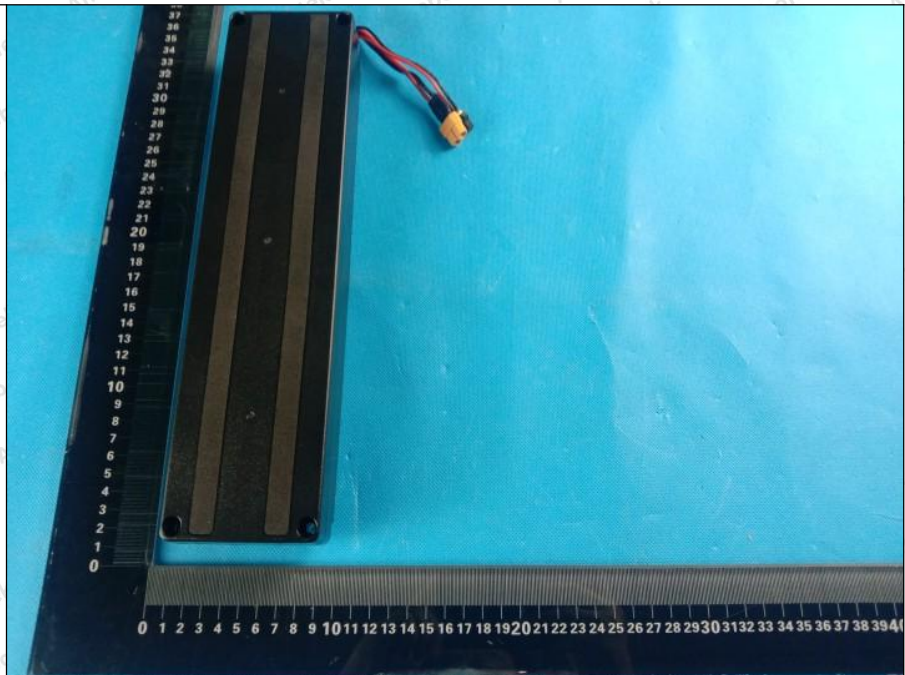

Photo 3

- front
- rear
- right side
- left side
- top
- bottom
- internal

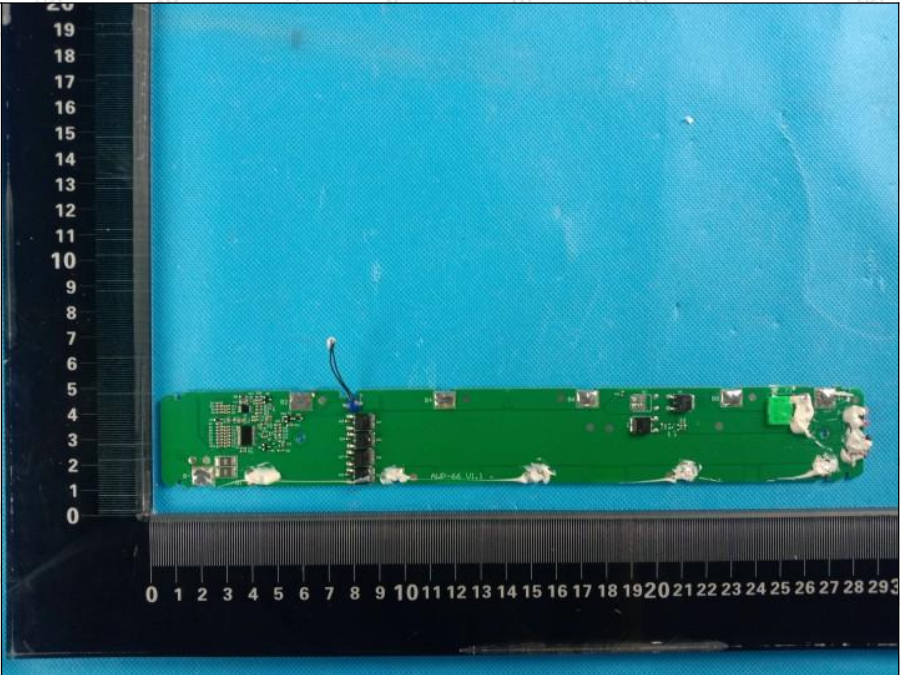

Photo 4

- front
- rear
- right side
- left side
- top
- bottom
- internal

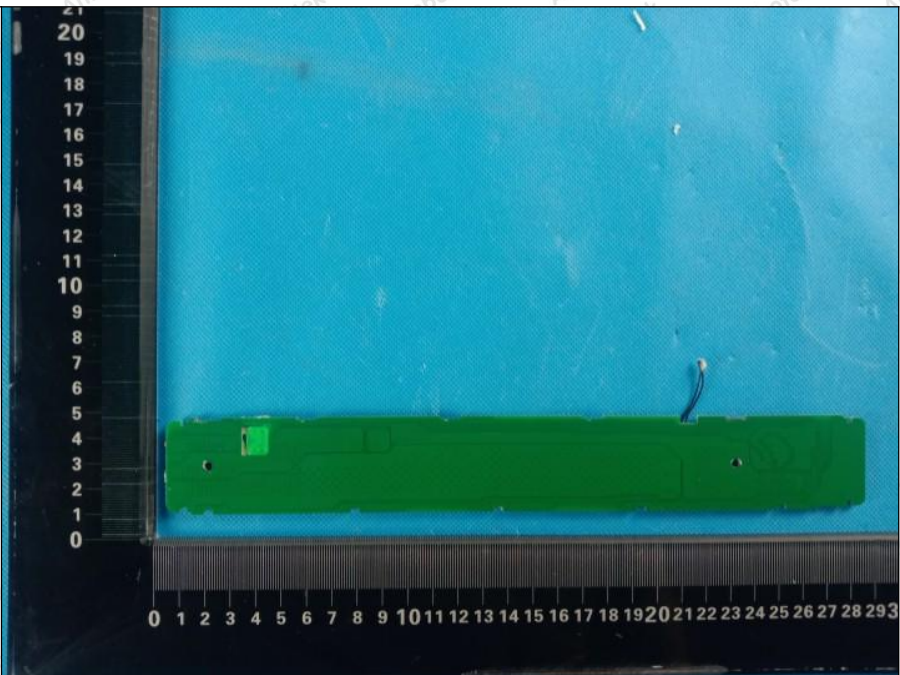

Photo 5

- front
- rear
- right side
- left side
- top
- bottom
- internal

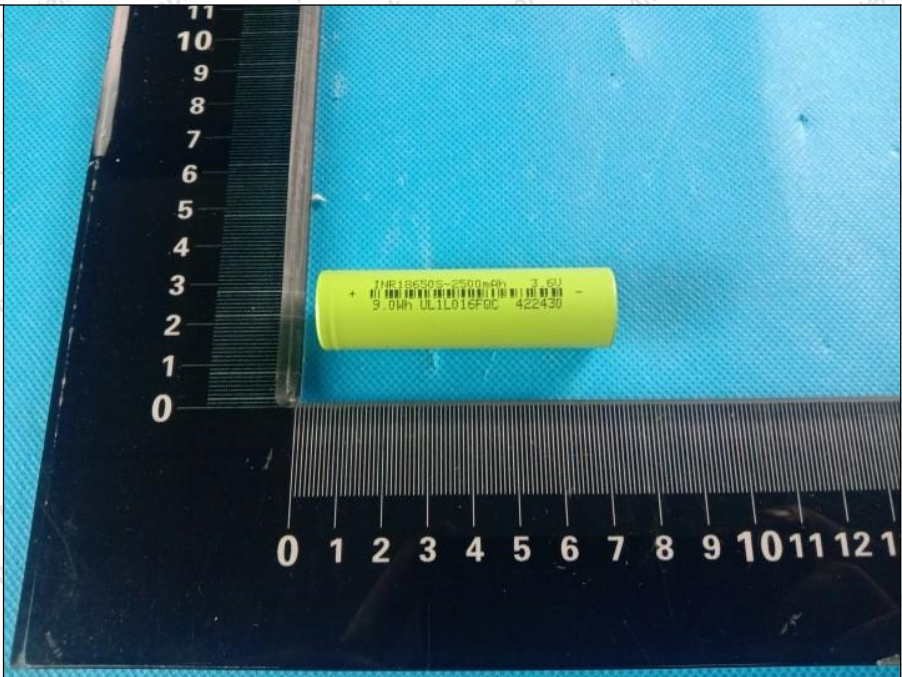
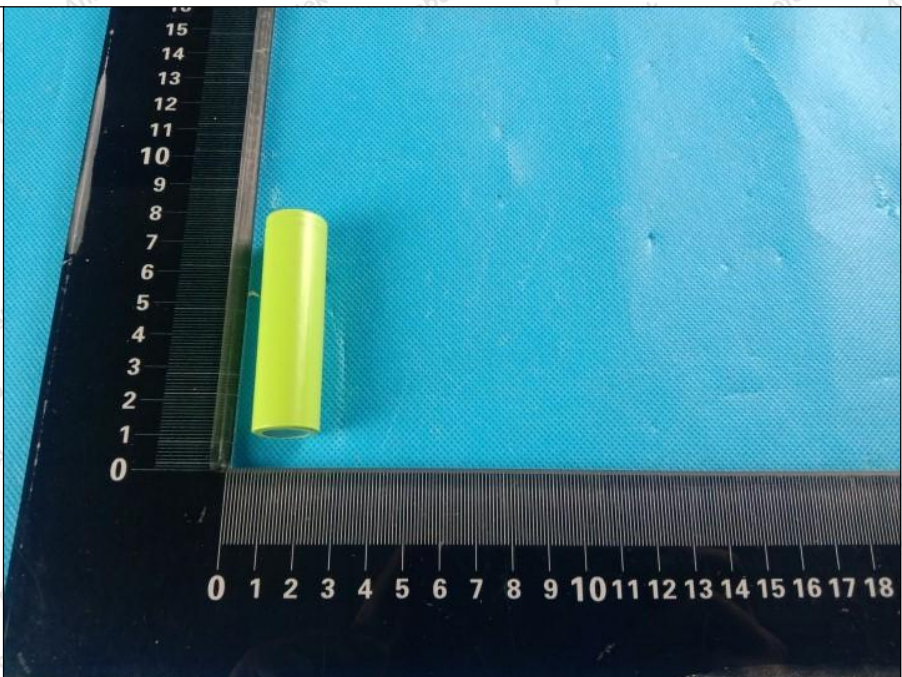

Photo 6

- front
- rear
- right side
- left side
- top
- bottom
- internal



End of the report