

Executive standard: GB17761-2018



Zhejiang iWalk Technology Co., Ltd.
Address: Building 59-1, Juxing Weichuang Technology Park, Xiachen Sud-District,
Jiaojiang District, Taizhou City, Zhejiang Province
Service Hotline: 400-883-9299
Official website: <https://www.zjiwalk.com/>

i·walk[®] **RS1**

Instruction Manual TDSRS1Z



WeChat public
account

The user should not use the electric bicycle before carefully reading the instruction manual to understand its performance.
Please keep this instruction manual properly. Service Hotline of
Zhejiang iWalk Technology Co., Ltd.: 400-883-9299 Official Website: <https://www.zjiwalk.com/>
Address: Building 59-1, Juxing Science and Technology Innovation Park, Xiachen Sud-District, Jiaojiang District, Taizhou
City, Zhejiang Province
Some specifications are subject to change without notice when the product is upgraded.
*Note: Due to the possible upgrade of the company's products, some of the content displayed on the actual product you
get will be different from its manual, but it will not affect your normal use.

Bicycle barcode

Here is where the
barcode is pasted

PRECAUTIONS FOR USE

Please obey traffic laws and pay attention to driving safety, such as:

- 1) It is strictly forbidden for persons under the age of 16 to drive electric bicycles on the road;
- 2) Electric bicycles should be driven in non-motorized vehicle lanes, and the maximum speed should not exceed 15km/h; on roads without on-motorized vehicle lanes, bicycle drivers shall drive on the right side of the roadway;
- 3) Please do not lend your electric bicycle to someone who cannot operate it to avoid personal injury or property damage;
- 4) Electric bicycles shall carry persons or items in accordance with the provisions of laws and regulations;
- 5) It is recommended to wear a helmet when riding this electric bicycle;
- 6) When riding in rainy and snowy days, the braking distance will be extended, so please pay attention to slow down; try to avoid traveling in bad weather such as heavy rain. Be sure to pay attention to the safety of electric bicycles, such as:

- 1) Electric bicycles should not be parked in building foyers, evacuation stairs, walkways as well as safety exits;
- 2) Electric bicycles should not be charged and parked in residential buildings, and should be kept away from combustibles when charging, and the charging time should not be too long;
- 3) Please refer to this manual for the correct use and maintenance of lithium batteries; Waste lithium batteries cannot be dismantled without authorization, and should be recycled by relevant professional departments;
- 4) Please refer to this manual for the safe use of the charger; For the warning words, please refer to the main body logo of the electrical appliance; When replacing the charger, the new charger should match the battery model;
- 5) Please refer to this manual for the precautions related to washing;
- 6) When adjusting the handlebars or saddles, be careful not to expose the safety line markings of the handlebar tube and saddle tube. Precautions for inspection before riding (if there is any abnormality, please repair it in time or seek the help of professional maintenance personnel), such as:
 - 1) Check the status of the power circuit, lighting circuit, etc.;
 - 2) Check whether the front-wheel brake and rear-wheel brake can work normally;
 - 3) Check the tightness of the handlebars and front and rear wheels;
 - 4) Check the tire pressure, the recommended range is 240-310kpa;
 - 5) Check the reflector for damage or soiling.

Battery and Charging

- Charge at 0°C to 45°C, discharge at -20°C to 60°C, and be sure to keep the battery dry;
- It is strictly forbidden to put the battery in acid or alkaline liquid, and please keep the battery away from rain, heat and high humidity and make sure the battery is kept away from fire.
- It is strictly forbidden to connect the positive and negative poles in reverse, to damage, dismantle or short-circuit the battery;

- When charging, please use the original special charger, do not use other brands of chargers without authorization, and the charging current should not exceed 3A. When not in use for a long time, please keep the battery in a cool and dry place, and charge the battery once a month;
- When charging, the electric bicycle should be placed in a ventilated environment, and it is strictly forbidden to charge in a confined space or in a high temperature environment under the scorching sun;
- When charging, plug in the battery first, and then turn on the mains power for charging; after charging is completed, first cut off the mains power, and then unplug the battery;
- When the green light is on, the power supply should be cut off in time, and it is forbidden to connect the charger to the AC power supply with no load for a long time without charging;
- During the charging process, if the indicator light is abnormal, there is a peculiar smell or the case of the charger is overheated, the charging should be stopped immediately, and the charger should be repaired or replaced;
- During the use and storage of the charger, be careful to avoid the entry of foreign objects, especially the inflow of water or other liquids, so as to avoid short circuit inside the charger;
- Do not disassemble or replace the components inside the charger by yourself.

Maintenance and riding

- Check whether the front and rear wheel screws are locked, and whether the pattern of the outer wheel is worn or cracked;
- It is forbidden to rinse with water, so as to avoid the hidden danger of accidents caused by internal electronic components and lines due to water seepage;
- Please use a cloth to wipe the stains of paint or plastic parts with a neutral detergent, and then wipe it with a dry cloth;
- Check whether the joints of various parts are normal, and whether the zipper of the brake cable is used in a lubricated state;
- If you do not use this electric bicycle for a long time, please pay attention to regular charging (generally every two months) to maintain your battery life;
- Please use lubricating oil to wipe the metal parts of the electric bicycle body for maintenance;
- It is strictly forbidden to fill the front and rear brakes, wheel steel and tires

If there is any change in the relevant information of this card,
please refer to the **i-waik** website

i-waik Maintenance
certificate

Product Information-03

Model: _____

Repaired Part(s): _____

Fault condition when
returning for repair: _____

Cause of fault: _____

Date of return: _____

Repair outlet name: _____

Repairman's signature: _____

Product Information-04

Model: _____

Repaired Part(s): _____

Fault condition when
returning for repair: _____

Cause of fault: _____

Date of return: _____

Repair outlet name: _____



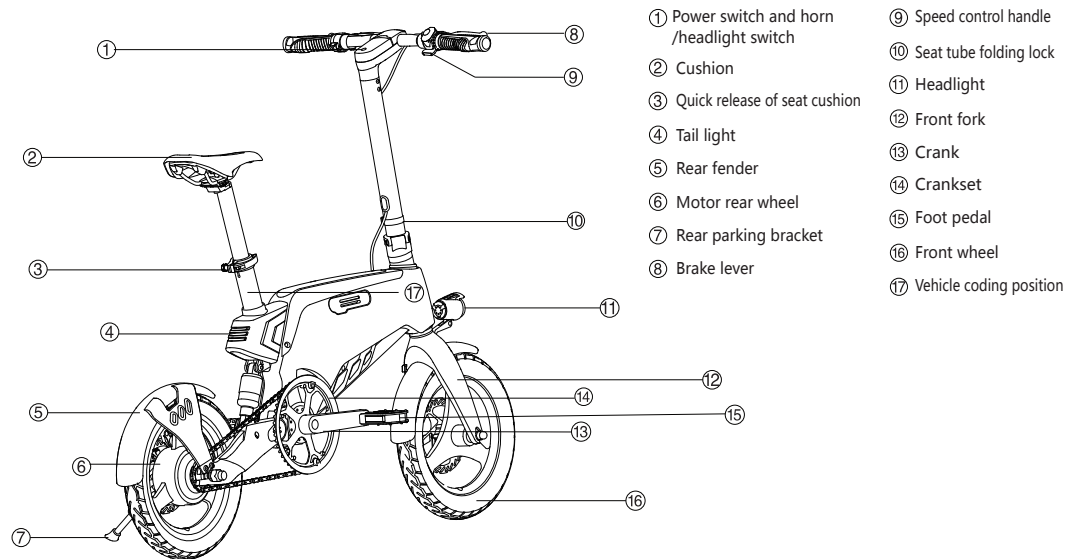

Repairman's signature: _____

Seal of Repair
department

RS1 Diagram



Packing list

 Body × 1	 Charger × 1	 × 1 Battery (built-in non-removable)	 Other accessories × 1	 User manual, Certificate of conformity, Three-guarantee card, After-sales service card
---	--	--	--	---

RS1 installation

 **1** Put down the parking bracket

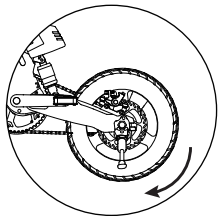

Take out the body of the electric bicycle and put down the foot support (as shown by the arrow on the right side of the picture)

 **2** Insert head tube

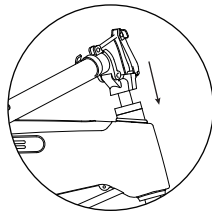

Insert the folded seat tube into the head tube and orient it as shown.

If there is any change in the relevant information of this card, please refer to the **i·WAIK** website

i·WAIK Maintenance certificate

User Information

Name: _____ Contact: _____ Email: _____

Address: _____

Product Information-01

Model: _____ Repaired Part(s): _____

Fault condition when returning for repair: _____ Cause of fault: _____

Date of return: _____ Repair outlet name: _____

Repairman's signature: _____

Product Information-02

Model: _____ Repaired Part(s): _____

Fault condition when returning for repair: _____ Cause of fault: _____

Date of return: _____ Repair outlet name: _____

Repairman's signature: _____

i-walk Three Guarantees Certificate

Three Guarantees Policy

The after-sales service of electric-assisted folding bicycles implements the after-sales three-guarantee service strictly in accordance with the provisions of the "Consumer Rights Law of the People's Republic of China" and the "Product Quality Law of the People's Republic of China". The specific services are as follows:

1. The "Three Guarantees" period is calculated from the date of sale of the electric bicycle (Vehicle Purchase Document must be issued). During the "Three Guarantees" period, customers can enjoy the "Three Guarantees" service by presenting the "Vehicle Purchase Document" and "Warranty Certificate" to the after-sales service station.
2. During the "Three Guarantees" period, if the motor of the electric bicycle has a related failure that affects its performance, and it still cannot be used normally after two repeated repairs within one month, consumers can apply to the seller for replacement of the same model of electric bicycle with the repair record and certificate of the i-Walk service station. If there are no products of the same model and consumers are unwilling to exchange products of other models, consumers can get a refund for return. When returning the product, the depreciation fee will be charged according to the relevant regulations in the "Three Guarantees" of electric bicycle products and parts. Depreciation charges are calculated from the date of invoice to the date of return.
3. The validity period of the "Three Guarantees" after replacement of electric bicycle and charger at the same time will be recalculated from the date of replacement. Consumers should obtain a new vehicle purchase receipt from the dealer. The "Three Guarantees" period after the replacement of the new battery (after the maintenance of the battery) shall be calculated according to the purchase date of the first payment, and the "Three Guarantees" period shall be accumulated.
4. The electric bicycle has irreparable faults such as cracking of the motor shell and damage to the winding caused by quality problems, or non-human factors such as welding, de-soldering and fracture of the frame and handlebar of the whole vehicle. Consumers can choose to repair, replace or return the electric bicycle within 7 days from the date of sale of the product. When returning the bicycle, the payment will be refunded according to the price of the vehicle purchase document; Within 8 to 15 days from the date of sale of the product, consumers can choose to repair or replace the bicycle. If the consumer chooses replace, the seller should replace the electric bicycle of the same model.
5. The faulty parts will be replaced free of charge during the "Three Guarantees" period.
6. If the last day of the "Three Guarantees" period is a statutory holiday, the "Three Guarantees" period will be extended to one working day after the statutory holiday.
7. After the product is sold, for the appearance damage of the electric bicycle that meets the conditions for Changing or Refunding([Note] including but not limited to not belonging to the scope of "Three Guarantees"), consumers should bear the corresponding accessories costs.
8. The after-sale service station will still provide repair and maintenance services for the failure of electric bicycles and its major parts beyond the scope of the "Three Guarantees" or beyond the "Three Guarantees" period, but will charge the repair service fee and the cost of the parts.
9. The daily depreciation rate of the complete vehicle and parts under "Three Guarantees" service are as follows: 0.2% for the complete vehicle; 0.3% for battery parts; 0.2% for other parts; Those who meet the conditions of Changing or Refunding shall be charged depreciation fee according to the following standards:
depreciation fee = invoice price x number of days of purchase x depreciation rate.
If your beloved electric bicycle has a non-human damage performance failure, please contact the seller to solve it at the first time (if the seller does not solve it or the service attitude is bad, you can complain directly through the official channel).

*The e-bikes sold overseas are excluded from this warranty term, as the standards vary in different countries.

After-sales service phone number: 400-883-9299

3 Twist the fastener

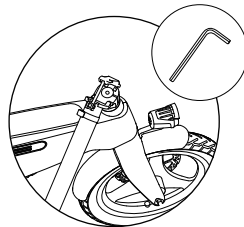

Secure with the L-shaped M6 internal hexagonal wrench that comes with the e-bike.

5 Adjust seat height

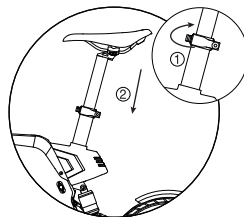

Open the seat tube lock (in the direction of arrow ① as shown in the figure), adjust the height of the seat cushion (in the direction of arrow ② in the figure), and lock the lock of the seat tube.

4 Push up the seat tube of the bicycle head

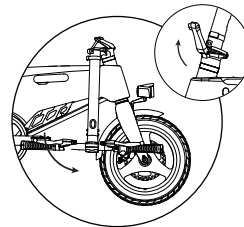

Push the seat tube of the bicycle head until it is vertically closed (in the direction of the arrow on the right side of the figure)

Close the lock (in the direction of the arrow on the right side of the figure), and you can hear a "click" sound (the lock is slightly tight, and you need to press it hard).

6 Install the pedals

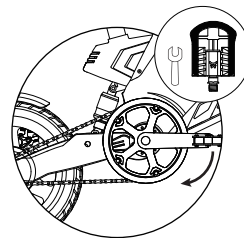

Install the pedals
Take out the right pedal (R), align it with the crank, and use an open-end wrench to rotate the pedal clockwise to install and tighten (in the direction of the arrow in the figure).
Take out the left pedal (L), align it with the crank of the crankset, and use an open-end wrench to rotate the pedal counterclockwise to install and tighten.

RS1 Meter Instructions for Use

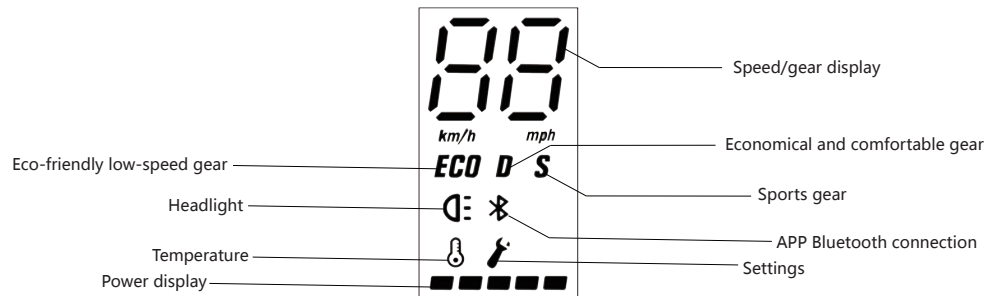

- • • 1. In the off state, press and hold the power button for 3 seconds to turn on (there is a power-on prompt tone) / in the power-on state, press and hold the power button for 3 seconds to turn off (buzzer beeping prompt).
 - 2. Keep the electric bicycle turned on, press the power button switch (short press) to turn on the headlights and taillights of the bicycle (the panel icon turns on and off with the lights, and the taillights are highlighted when braking).
 - 3. Keep the electric bicycle turned on. Double-click the power button (short press 2 times in a row) to switch gears (low speed/comfort/sport) back and forth, and you can also switch gears through the mobile APP interface.
 - 4. Through the APP mobile phone connection, the body atmosphere light can be turned on and off, and the flashing mode and light color of the body atmosphere light can also be customized.
 - 5. Switch the speed unit through the APP mobile phone connection or by pressing the power button 3 times in a row on the instrument (default Km/h).
 - 6. Battery displays real-time battery/vehicle speed displays real-time vehicle speed.
 - 7. The mobile phone is connected to the vehicle through the APP, and the Bluetooth icon is turned on (the APP can set the vehicle, which can realize electronic locking, atmosphere light control, gear switching and other rich functions).
 - 8. Non-zero start, the motor with speed greater than 5Km/h provides assistance (or start) (Press the power switch 5 times continuously to switch to zero start, the default is non-zero start when booting).
 - 9. After the automatic cruise function is turned on through the APP mobile phone connection, the speed is maintained at a certain speed for 8S to enter the constant speed cruise, and exit cruise by toggling the thumb shifter or applying the brakes.
- In addition: In line with 3C standards, the alarm will sound when the speed reaches 15Km/h, and the maximum speed provided is 25Km/h. **If the taxiing speed exceeds this speed, the buzzer will give an alarm.**

iWALK Warranty Policy

Serial number	Parts	Warranty period (months)	Scope of warranty	
1	Battery	10.4AH	6	Less than 60% battery capacity detected within 12 months
2		Excluding 10.4AH	6	Less than 60% battery capacity detected within 18 months
3	Motor	12	Performance failure (man-made unauthorized disassembly, water ingress will not be guaranteed)	
4	Controller/Charger/Instrument	12	Performance failure (man-made unauthorized disconnection and disassembly will not be guaranteed)	
5	Frame	12	Performance failure	
6	Pedal/Disc Brake/Brake/Foot Support	1	Performance failure	
7	Brake line / mudguard / inner and outer tires / spokes / saddle / plastic wearing parts are not guaranteed			
8	6 months warranty for other unspecified parts			

Disclaimer of the Three Guarantees Policy

1. The validity period of the three guarantees has expired;
2. Damage caused by force majeure;
3. If there is no "vehicle purchase document" and "warranty card" or the purchase document and warranty card do not match the actual vehicle;
4. The frame number and motor number do not match the certificate;
5. The serial number of the frame has been damaged in the case of unauthorized repair, misuse, collision, negligence, abuse, accident, modification, improper use of this product without the authorization of the company;
6. Failure to present valid document (valid invoices) or purchase document does not match the actual vehicle data;
7. Failure to perform proper maintenance in accordance with the instruction manual;
8. The sound or vibration produced by the rotatable parts of the pedals, front and rear hubs, steering system, shock absorbers, flywheels, etc. will not affect the general function;
9. Due to external environmental factors such as sweat, collision, friction, etc., the paint surface of the frame and parts is corroded or peeled off, or due to poor storage or long-term use, the paint peels off, and the metal surface or plastic parts naturally fade;
10. When the electric bicycle is used beyond the specified scope of use (such as performing stunts, going down stairs, jumping, etc.), causing damage to its parts or failure of its functions;
11. Deformation or cracking of the frame due to over-use is not covered by the warranty;
12. The built-in non-rechargeable battery (dry battery, button battery) of the sensor is not covered by the warranty; the user needs to replace the battery at his/her own expense;
13. Consumables and wearing parts, such as chains, bells, handlebar grips, wire buckles, and tool accessories provided are not covered by the warranty;
14. Changes in battery capacity due to temperature changes in the use environment, battery power loss, bulging and damage caused by external factors, battery water ingress, charging with a charger not specified by IWALK, and modification and disassembly without the company's authorization, resulting in damage to the battery structure, are not covered by the warranty;
15. Chargers, controllers, etc. with trademarks and strip seals that have been torn up without permission will not be entitled to "Three Guarantees" service, and if the set of lock keys is broken and keys are lost, "Three Guarantees" service will not be granted;
16. Failures caused by force majeure (Note) such as floods, fires, earthquakes, lightning strikes, typhoons, inundation, chemical corrosion, etc.);
17. Consumables, such as insurance sheets, light bulbs, etc., exceed the specified warranty period;
18. Maliciously alter the "Three Guarantees" verification date of parts;
19. Advertising promotions, gift items, noise levels, soft and hard feelings and other human perception categories.

RS1 Electrical schematic diagram

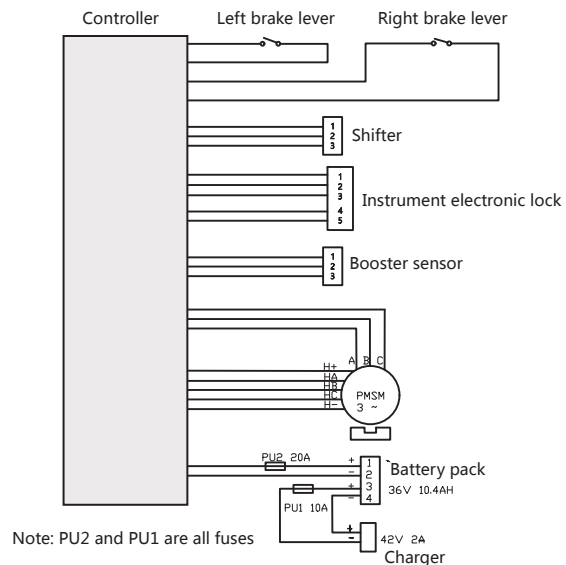

RS1 Battery installation location diagram

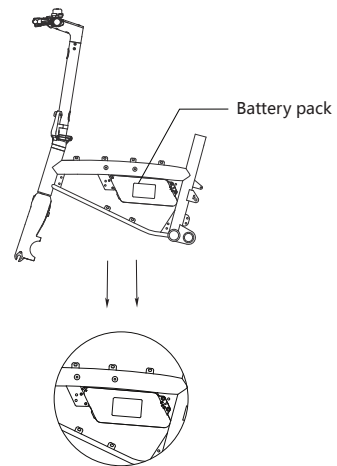

The battery pack (as shown above) is fastened to the frame with four screws.

7 Install the rear fender

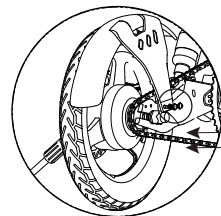

Take out two M5 screws and round washers and fix them with the L-shaped 4mm internal hexagonal wrench provided with the vehicle.

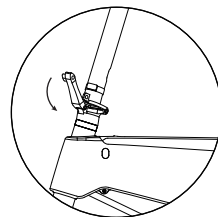

Open the e-bike head lock (as shown by the arrow on the right side of the figure).

8 Stabilize frame, fold the seat tube of the e-bike head

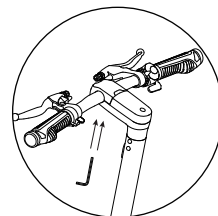

Straighten the handle and fasten the e-bike head lock.

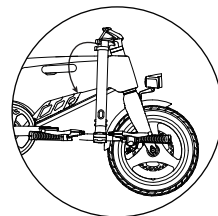

Fold down the head tube of the electric bicycle (as shown in the left direction of the figure) to complete the folding of the whole vehicle.

RS1 Starts

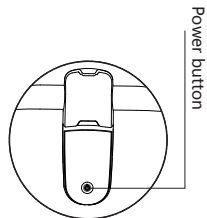

1. Press the black starter button under the handlebars to turn on the power.

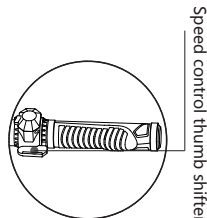

2. Open the foot support and ride on the RS1. When the riding speed reaches 5 yards, the electric assist effect will start, and press the speed control thumb shifter to respond in pure electric mode..

Other function description



RS1 Body atmosphere light on and off

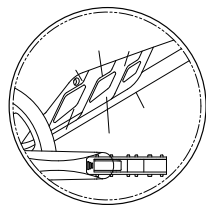

The body atmosphere light will automatically remember the lighting state of the last ride
If you want to turn off the body atmosphere light, you can do the following:

1. Keep the electric bicycle turned on.
2. Turn on the bluetooth on the mobile phone to connect the vehicle through the APP;
3. You can view the body atmosphere light switch options through the APP interface, and turn it on and off.

In addition: the flashing mode of the body atmosphere light can be controlled through the APP interface, and supports rich modes such as monochrome, monochrome breathing, music rhythm, etc.

RS1 Product parameters (TDSRS1Z)

Product Size	L1260mmx H1056mmx W540mm	Brake system	Mechanical brake + electronic brake
Total bicycle weight	20kg	Motor type	Permanent magnet motor
Load capacity	75kg	Rated voltage/nominal power	36V/250W
Frame material	Aluminum-magnesium alloy	Rated speed	420rpm \pm 10
Tire	14x2_125 (thick anti-skid tires for electric vehicles)	Motor Controller	KCF06G2Uv201707-36/250//6F3D-SA02AWK
Saddle	New ergonomically comfortable model	Undervoltage protection value (V)	30 \pm 1V
Nominal voltage/battery capacity	36V/10.4Ah	Overcurrent protection value (A)	13 \pm 1A
Top speed	25km/h	Speed control system	Single speed
Power consumption per 100 kilometers	0.80kw.h/100km	Kinetic energy recovery	Intelligent kinetic energy recovery system
Charging time	4-5h	Battery management system	Intelligent battery management system
Charging voltage	220V	Battery type	Lithium battery
Endurance mileage	40KM (pure electric) / 60KM (assist)	Three modes	Electric mode/assist mode/riding mode
Front and rear wheel center distance	910mm	LCD instrument	Speed display/battery display/Bluetooth APP/fault prompt